

SR-L6111W  
SF-L6111W



**Undercounter  
Scientific Grade  
Laboratory  
Refrigerators &  
Freezers**



**Features:**

- Enhanced preservation of laboratory and pharmacy materials, with high performance refrigeration, control and alarm/monitoring systems
- Ideally suited for vaccine storage in clinics, hospitals, retail pharmacies and laboratories

**Panasonic... the new name for SANYO**

*[www.panasonic.com/biomedical](http://www.panasonic.com/biomedical)*

# Undercounter Refrigerators and Freezers

Designed for the demanding standards of clinical, life science, pharmaceutical, biotechnology, and industrial laboratories. The Panasonic freestanding or Under the Counter Scientific Grade Laboratory Refrigerator features Panasonic designed and manufactured compressors and key components, stringent quality control processes, and is the highest quality laboratory appliance available today.

## Undercounter Refrigerators

Model Number	Volume (cu.ft.)	Exterior Dimensions (w x f-b x h)	Temperature	Display	Lock	Voltage, Power Connection
SR-L6111W-PA	6.1 173 L	23.6" x 26.2" x 34.6"* 600 x 660 x 879 mm	1°C to 14°C Microprocessor Controlled	yes	yes	115V, NEMA 5-15
SF-L6111W-PA	5.4 153 L	23.6" x 26.2" x 34.6"* 600 x 660 x 879 mm	-15°C to -20°C Microprocessor Controlled	yes	yes	115V, NEMA 5-15

Convenient compact refrigeration in a laboratory environment.

\*Cabinet depth measures 24" f-b without display and 26.2" f-b with display



### Laboratory and Clinical Design

- Door mounted controller
- Digital input of temperature allows end user temperature flexibility
- Integrated electronic and microprocessor technology for proven quality
- Feature stable temperature and uniformity for scientific grade preservation

### Microprocessor Temperature Controls

Comprehensive temperature set point with adjustable range from 1°C to 14°C, preset alarm at  $\pm 3^\circ\text{C}$  from temperature setpoint, monitoring based on a sophisticated microprocessor controller with digital display.



# Undercounter Refrigerators and Freezers

## Accessibility and Safety

- Easy to read, angled LED display and keypad
- Digital input of temperature with setpoint range from 1°C to 14°C allows end user temperature flexibility
- Remote alarm contacts for connecting to a centralized alarm monitoring system
- Automatic tracking alarm around setpoint monitors critical temperature variances
- Door ajar alarm with alarm delay timer eliminates nuisance alarms
- Controller lockout function prevent setpoint tampering

## Forced Air Circulation in Cabinet

Quickly restores temperature uniformity following routine door openings

## Secured Door

Keyed door is lockable. Optional padlock hasp allows for additional security.



## Built-in Front Breather Design

Allows unit to be built in under bench or counter and requires no additional clearance top, back, and sides.

## Compact Design

Allows for easy installation under counter, counter top, or within the knee-well of laboratory cabinetry. Door shelves and standard shelving maximize product storage capacity. Some models are stackable.

## Stackable Construction

Units can be stacked and secured with stacking plates.

## JCAHO Standards

SR-L6111W and SF-L6111W meets JCAHO standards for controlling medication access.

## Dimensional Drawings

SR-L6111W

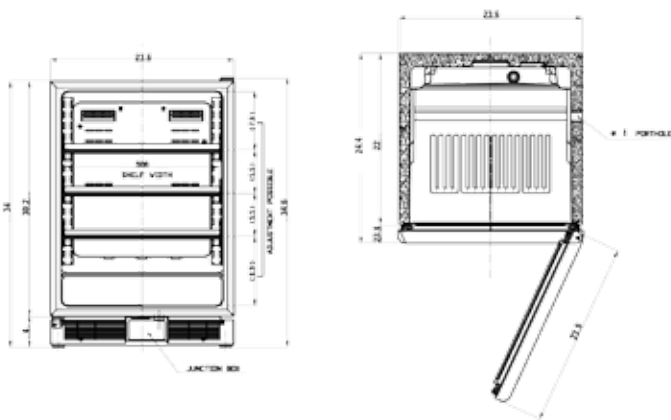

SF-L6111W

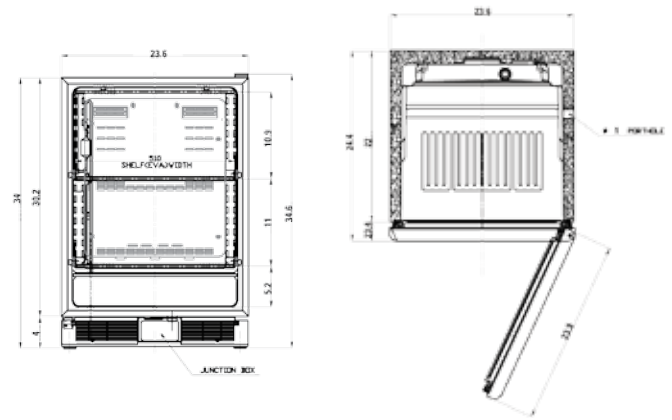

# Scientific Grade Undercounter Specifications

## Specifications

### Description

Model Number	SR-L6111W-PA (Refrigerator)	SF-L6111W-PA (Freezer)
Internal Capacity & Volume	6.1 cu.ft. 173 L	5.4 cu.ft. 153 L
Exterior Dimensions (w x f-b x h)	23.6 x 34.5" x 25.6" 600 x 876 x 652 mm Unit depth with hinge: 34.3", Unit depth with hinge cap: 34.5"	23.6 x 34.5" x 25.6" 600 x 876 x 652 mm Unit depth with hinge: 34.3", Unit depth with hinge cap: 34.5"
Clearance Requirements	No clearance required from top, back and sides of cabinet	No clearance required from top, back and sides of cabinet
Refrigeration System	Panasonic built compressor, R134A HFC "Green" refrigerant, and zero clearance front-breather condensor design	
Temperature Control	Forced air circulation with microprocessor digital input	Evaporator shelf cooling with manual defrost
Temperature Setpoint Range	1°C to 14°C	-15° to -20°C
Alarm Range	Tracking alarm $\pm 3^{\circ}\text{C}$ around setpoint, remote alarm contacts	
Access Port	13/16" (30mm) hole diameter	
Interior Storage	3 adjustable wire shelves	2 Fixed evaporator shelves
Door Swing	Right hand hinged door swing	
Security Features	Keypad lockout feature, keyed door lock, optional padlock hasp (not included)	
Electrical Requirements	115V, 60Hz, NEMA 5-15 Receptacle	
Weight	110 lbs. 50 kg	110 lbs. 50 kg



**Panasonic Healthcare Company of North America**  
 1300 Michael Drive, Suite A, Wood Dale, IL 60191  
 Toll Free USA (800) 858-8442, Fax (630) 238-0074  
[www.panasonic.com/biomedical](http://www.panasonic.com/biomedical)

© Panasonic Printed in USA 2012.02 AU  
 AU201202V1